

ILLUSTRATED PARTS LIST

MODEL NO. 96061010000

CUSTOMER CATALOG NO. M155B107HRB

PRODUCT NO. 960 61 01-00

REPAIR PARTS

TRACTOR -- MODEL NO. M155B107HRB (96061010000), PRODUCT NO.960 61 01-00
DECALS

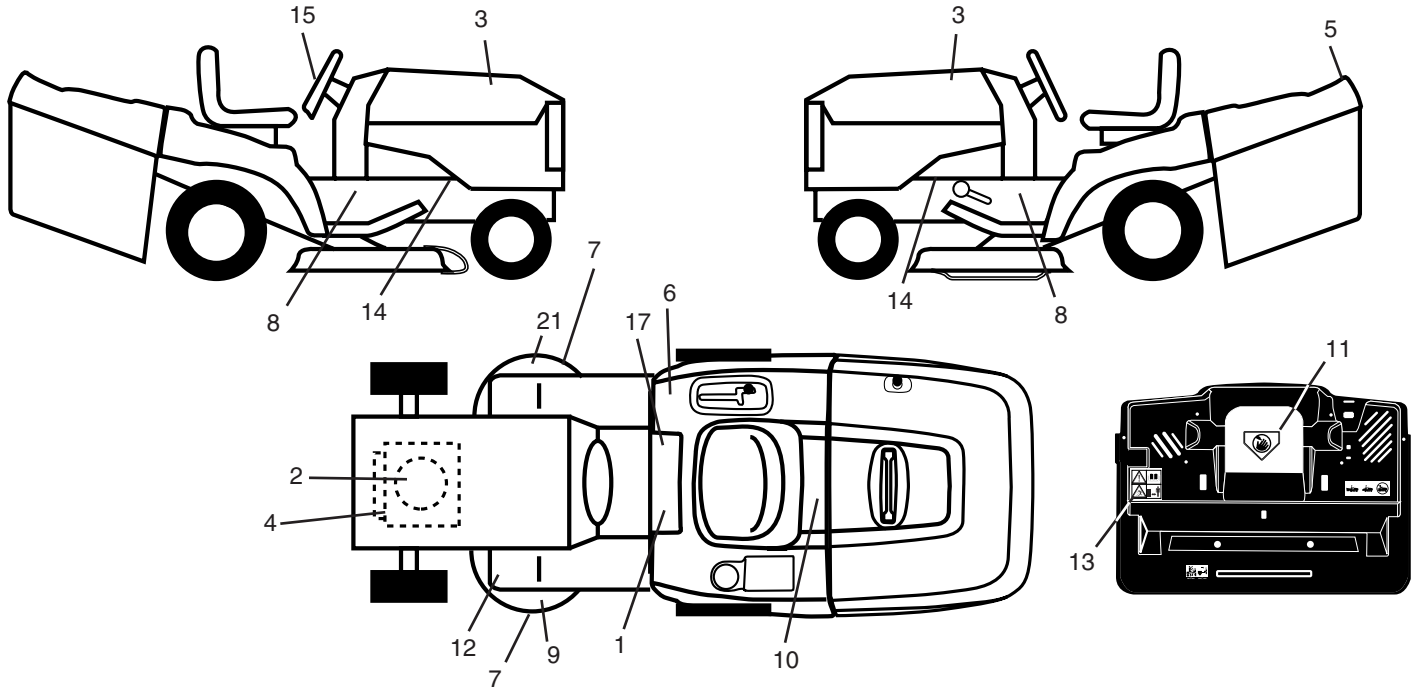

KEY NO.	PART NO.	DESCRIPTION
1	532 40 03-89	Decal, Warning Syms. CE
2	532 19 80-65	Decal, Hp Engine
3	532 40 20-32	Decal, Hood
4	532 19 68-41	Decal, Warning Eng. Syms.
5	532 40 19-02	Decal, Fndr
6	532 18 04-32	Decal, 100 DBA/CE
7	532 19 68-42	Decal, SDL SHF/CRD Sym. Cutfinger
8	532 40 11-46	Decal, Warning
9	532 18 78-11	Decal, Mower Enviro
10	532 14 50-05	Decal, Bat Dan/Poi P/L Sym Wpn
11	532 18 21-66	Decal, Mower Cut Finger CE

KEY NO.	PART NO.	DESCRIPTION
12	532 15 97-37	Decal, Brake/Clutch Symbol Lt
13	532 18 04-35	Decal, Warn Back Plate CRD
14	532 15 97-36	Decal, Chassis Hot Muffler
15	532 40 18-60	Decal, Steering Wheel
17	532 14 08-37	Decal, Saddle Brake Parking
21	532 16 62-86	Decal, Hex Belt Sch 92 CRD
--	532 13 83-11	Decal, Lift Handle
--	532 16 69-60	Decal Bypass
--	532 18 10-91	Pad Footrest LH
--	532 18 10-90	Pad Footrest RH
--	532 40 09-09	Manual Operator's (Euro)

WHEELS & TIRES

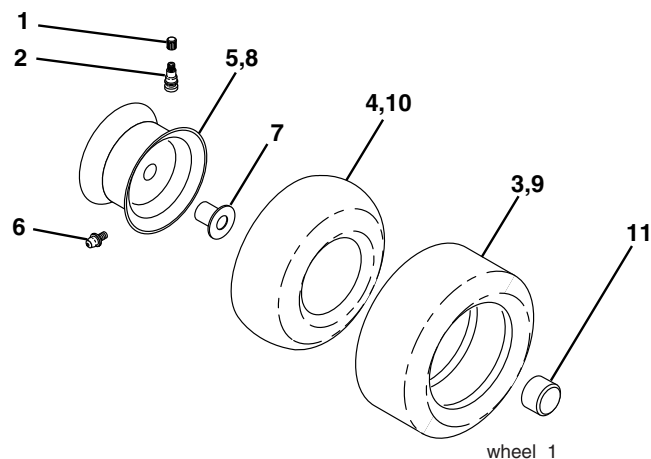

KEY NO.	PART NO.	DESCRIPTION
1	532 05 91-92	Cap Value Tire
2	532 06 51-39	Stem Value
3	532 10 62-22	Tire F Ts 15 x 6 0 - 6 Service
4	532 05 99-04	Tube Inner Front #35060
5	532 12 51-21	Rim Asm 6" front Service
6	532 12 49-57	Fitting Grease
7	532 12 49-59	Bearing Flange
8	532 12 51-22	Rim Asm 8" rear Service
9	532 13 84-68	Tire R Ts 20 x 8-8 C.Service
10	532 12 49-26	Tube Rear 9 5 x 8 Service
11	532 17 50-39	Cap Axle Blk 1 50 x 1 00
--	532 14 43-34	Sealant, Tire (10 oz. tube)

NOTE: All component dimensions given in U.S. inches
1 inch = 25.4 mm

TRACTOR - - MODEL NO. M155B107HRB (96061010000), PRODUCT NO.960 61 01-00 SCHEMATIC

03055_197436 (WITH LIGHTS)

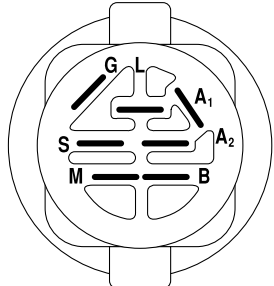
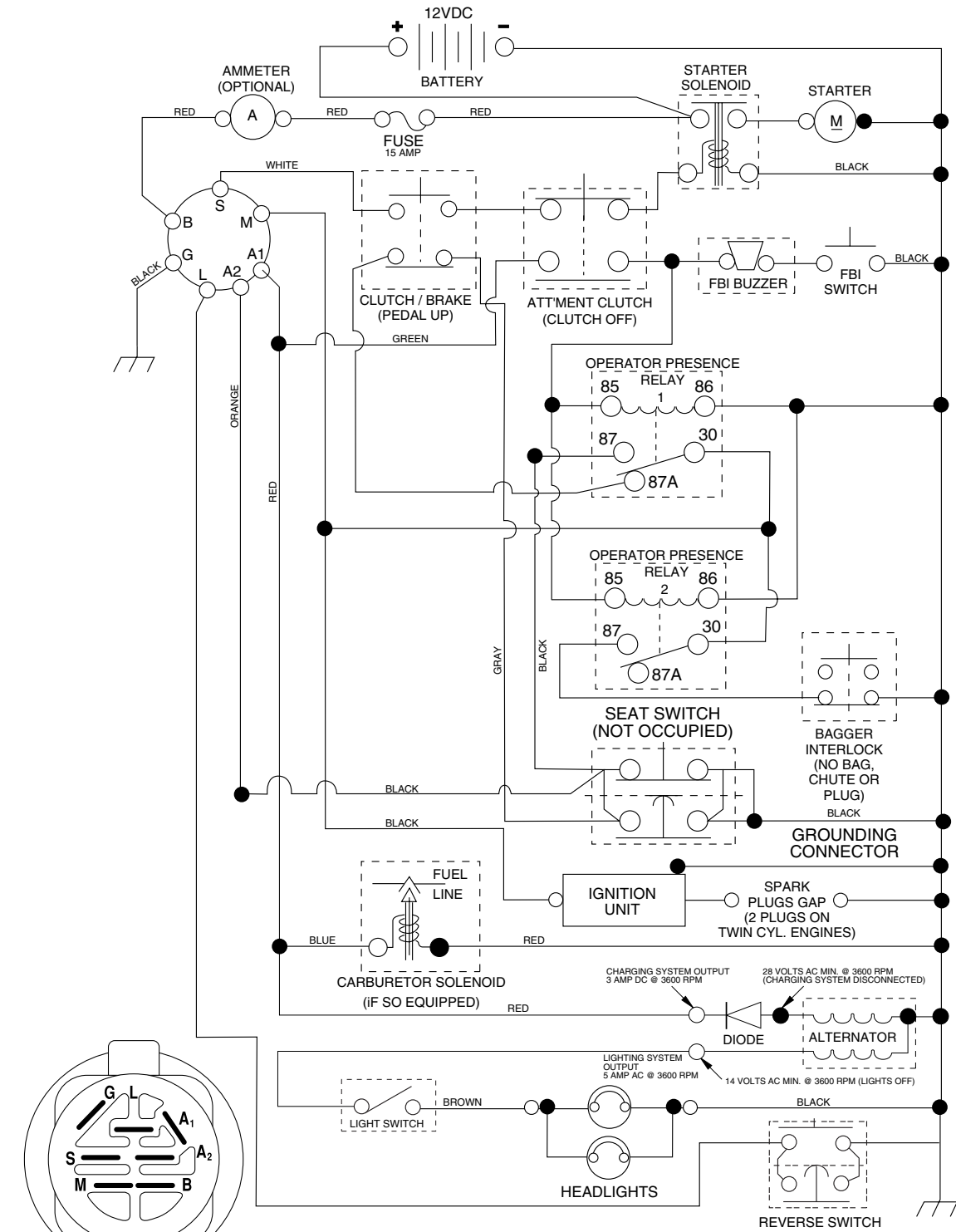

IGNITION SWITCH

POSITION	CIRCUIT	"MAKE"
OFF	M+G+A1	
RUN/OVERRIDE	B+A1	
RUN	B+A1	L+A2
START	B + S + A1	

WIRING INSULATED CLIPS

NOTE: IF WIRING INSULATED CLIPS WERE REMOVED FOR SERVICING OF UNIT, THEY SHOULD BE REPLACED TO PROPERLY SECURE YOUR WIRING.



REMOVABLE CONNECTIONS



NON-REMOVABLE CONNECTIONS

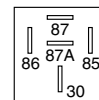

RELAY

03055

REPAIR PARTS

TRACTOR -- MODEL NO. M155B107HRB (9606101000), PRODUCT NO.960 61 01-00
ELECTRICAL

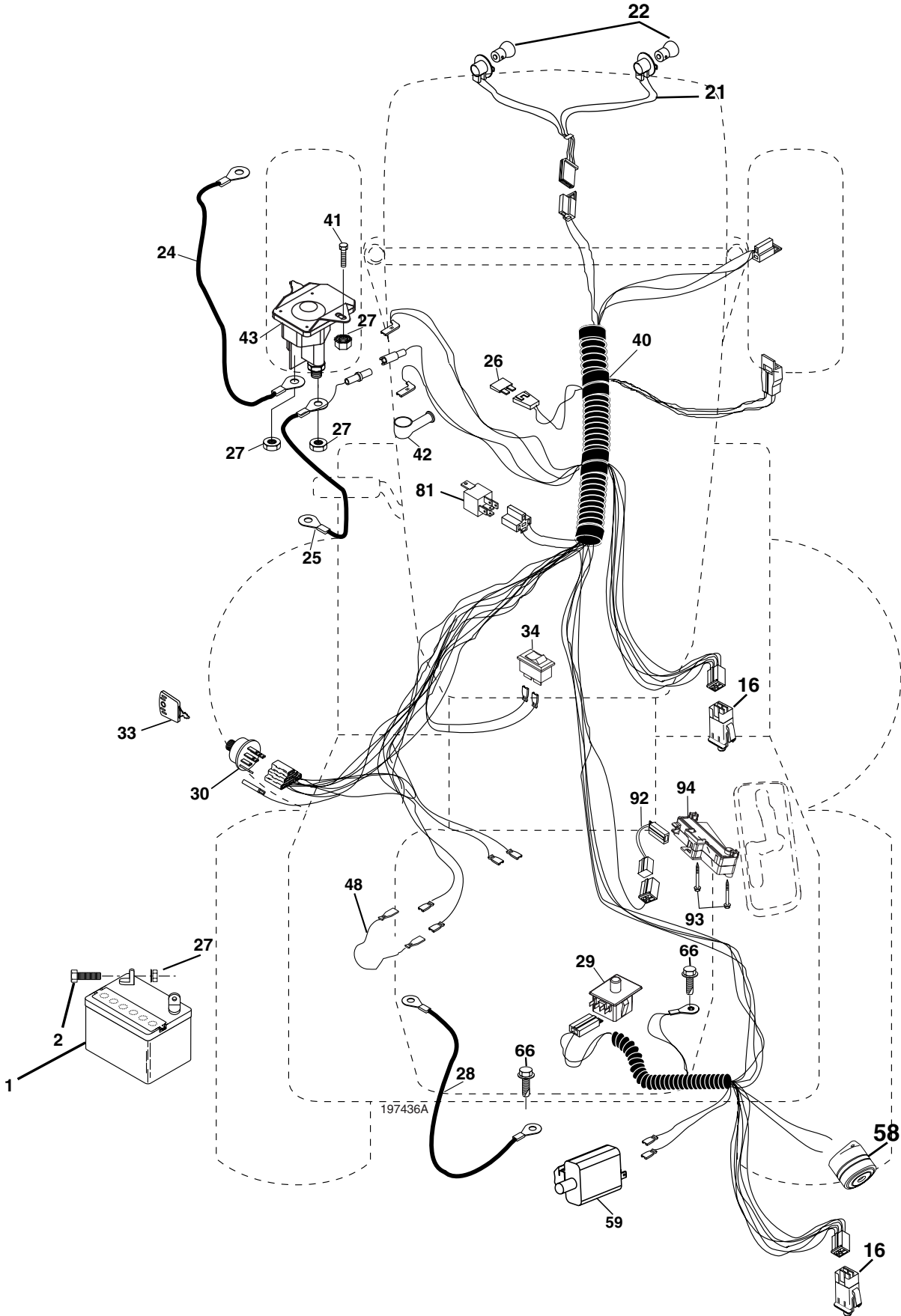

REPAIR PARTS

TRACTOR - - MODEL NO. M155B107HRB (96061010000), PRODUCT NO.960 61 01-00
ELECTRICAL

KEY NO.	PART NO.	DESCRIPTION
1	532 16 34-65	Battery
2	874 76 04-12	Bolt Hex Hd 1/4-20 unc x 3/4
16	532 17 61-38	Switch Interlock Push-In
21	532 18 37-59	Harness Asm. Light
22	532 00 41-52	Bulb Light #1156
24	532 12 47-80	Cable Starter 6 Ga. 11" Red
25	532 16 59-87	Cable Battery Crd 56" Red
26	532 17 51-58	Fuse 20 Amp
27	873 51 04-00	Nut Keps Hex 1/4-20 unc
28	532 12 77-25	Cable Ground 6 Ga. 18" Black
29	532 19 27-49	Switch Seat
30	532 19 33-50	Switch Ignition
33	532 14 04-01	Key Ign
34	532 11 07-12	Switch Light/Reset
40	532 19 74-36	Harness Ign
41	871 11 04-08	Bolt Flk Fin Hex 1/4-20 unc x 1/2
42	532 13 15-63	Cover Terminal Red
43	532 19 25-07	Solenoid
48	532 14 08-44	Adapter Ammeter Rectangular
58	532 16 94-19	Buzzer Crd
59	532 18 03-79	Switch FBI CRD
66	817 49 06-08	Screw Thdrol 3/8-16 x 1/2 Ty-Tt
81	532 10 97-48	Relay Asm
92	532 19 66-15	Harness Pigtail
93	532 19 25-40	Screw Plastite 10-14 x 2.0
94	532 19 18-34	Module Reverse ROS

NOTE: All component dimensions given in U.S. inches.
1 inch = 25.4 mm.

REPAIR PARTS

TRACTOR -- MODEL NO. M155B107HRB (9606101000), PRODUCT NO.960 61 01-00
CHASSIS AND ENCLOSURES

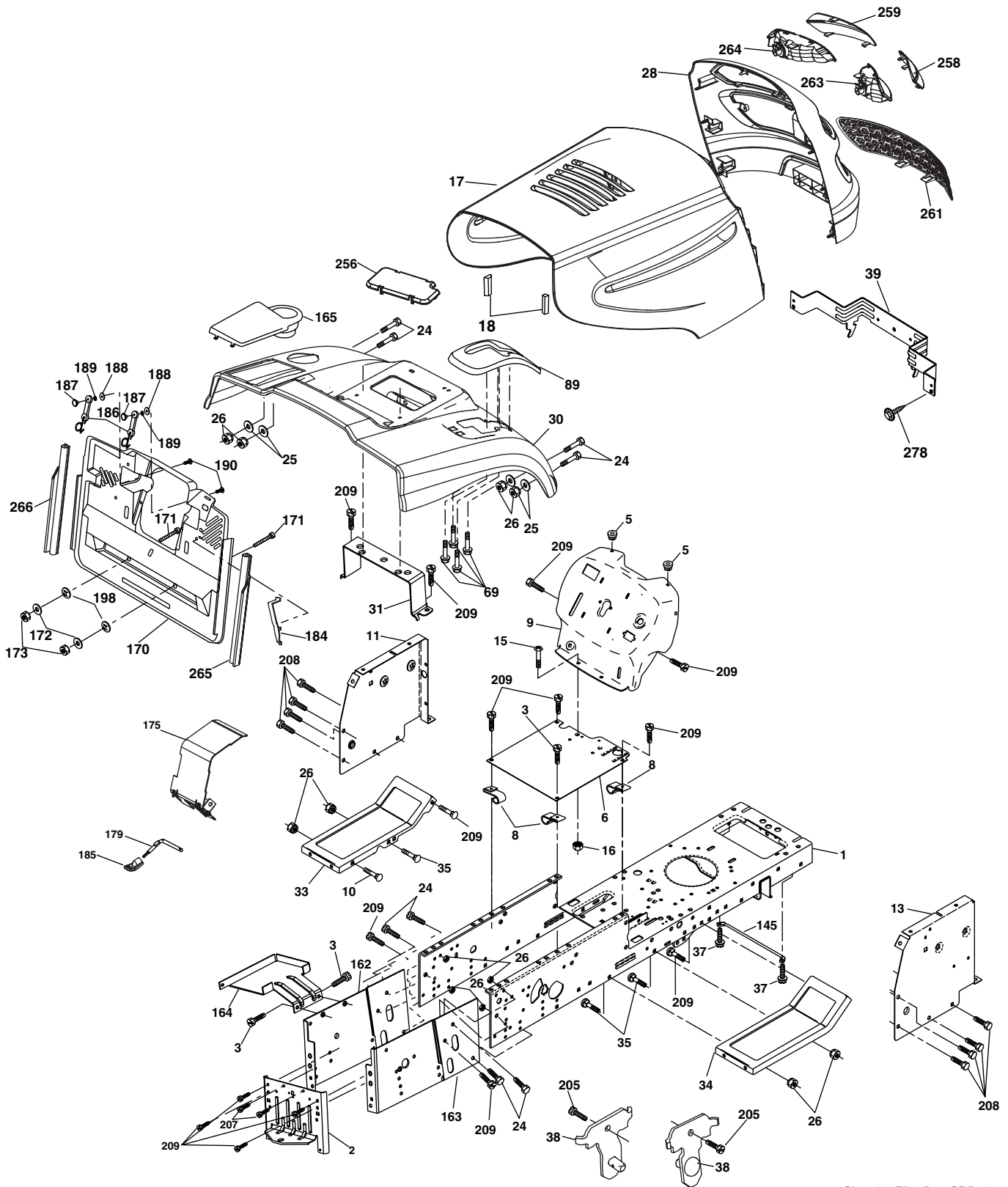

Chassis_Elite Pro_CRD_1

REPAIR PARTS

**TRACTOR - - MODEL NO. M155B107HRB (96061010000), PRODUCT NO.960 61 01-00
CHASSIS AND ENCLOSURES**

KEY NO.	PART NO.	DESCRIPTION	KEY NO.	PART NO.	DESCRIPTION
1	532 17 46-20	Chassis	164	532 16 56-05	Support Battery CRD
2	532 18 03-84	Drawbar	165	532 18 13-56	Cover Battery CRD Lt
3	817 06 06-12	Screw 3/8-16 x .75	170	532 19 94-88	Backplate CRD
5	532 15 52-72	Bumper Hood/Dash	171	872 14 06-20	Bolt Rdhd Sqnk 3/8-16 x 2-1/2 Gr. 5
6	532 18 44-19	Saddle	172	819 13 20-16	Washer 13/32 x 1-1/4 x 16 Ga.
8	532 12 64-71	Clip Insulator 13/32 Mtg. Hole	173	873 51 06-00	Nut, Keps Hex 3/8-16 unc
9	532 19 46-88	Dash	175	532 18 82-03	Trap Door CRD
10	872 14 06-08	Bolt, Carriage 3/8-16 x 3/4	179	532 18 82-02	Rod Pivot FBI CRD
11	532 17 49-96	Panel, Dash, L.H.	184	532 17 46-62	Bracket Actuator Bagger CRD
13	532 18 69-52	Panel, Asm. Dash R.H.	185	532 18 11-01	Knob Rod
15	874 18 05-12	Screw, Machine, Truss Head 5/16-18 unc x 3/4	186	532 16 07-93	Latch Asm Multch Bagger
16	873 51 05-00	Nut	187	532 12 50-04	Nut Weld .327/.304 #10-24
17	532 18 65-80	Hood Assembly	188	819 06 12-16	Washer #10
18	532 18 49-21	Bumper Hood	189	810 07 10-00	Washer Lock #10
24	874 78 06-16	Bolt	190	871 08 10-10	Screw Pan Hd Phillips 10-24 x 5/8
25	819 13 13-12	Washer 13/32 x 13/16 x 12 Ga.	198	532 16 89-37	Nut Push
26	873 80 06-00	Nut	205	817 49 06-08	Screw 3/8-16 x 1/2
28	532 18 82-24	Grille Lens Asm	207	817 67 05-08	Screw THDROL 5/16-18 x 1/2
30	532 19 73-64	Fender	208	817 67 06-08	Screw Thdrol 3/8-16 x 1/2
31	532 16 51-56	Bracket, Fender Support	209	817 00 06-12	Screw Hex Wsh Thdrol 3/8-16 x 3/4
33	532 18 25-07	Footrest, L.H.	256	532 18 13-61	Cover Fender Rack CRD
34	532 18 25-08	Footrest, R.H.	258	532 18 97-55	Lens Grille RH
35	872 11 06-06	Bolt	259	532 18 97-54	Lens Grille LH
37	817 49 05-08	Screw Thdrol 5/16-18 x 1/2 TYT	261	532 18 97-53	Insert Grille
38	532 18 17-48	Bracket Asm Pivot Mower Rear	263	532 18 38-33	Bezel Grille RH
39	532 17 47-14	Bracket Pivot Laser	264	532 18 38-32	Bezel Grille LH
69	532 14 24-32	Screw Hex 1/4-1/2	265	532 18 57-04	Seal Side RH Bagger
89	532 19 73-66	Console	266	532 18 57-03	Seal Side LH Bagger
145	532 15 65-24	Rod Pivot Chassis/Hood	278	532 19 16-11	Screw 10 x 3/4 Single Lead Hex
162	532 18 03-82	Bracket Exten Chassis Lh CRD	- -	532 00 54-79	Plug, Button
163	532 18 03-83	Bracket Exten Chassis Rh CRD			

NOTE: All component dimensions given in U.S. inches.
1 inch = 25.4 mm.

REPAIR PARTS

TRACTOR -- MODEL NO. M155B107HRB (9606101000), PRODUCT NO.960 61 01-00
DRIVE

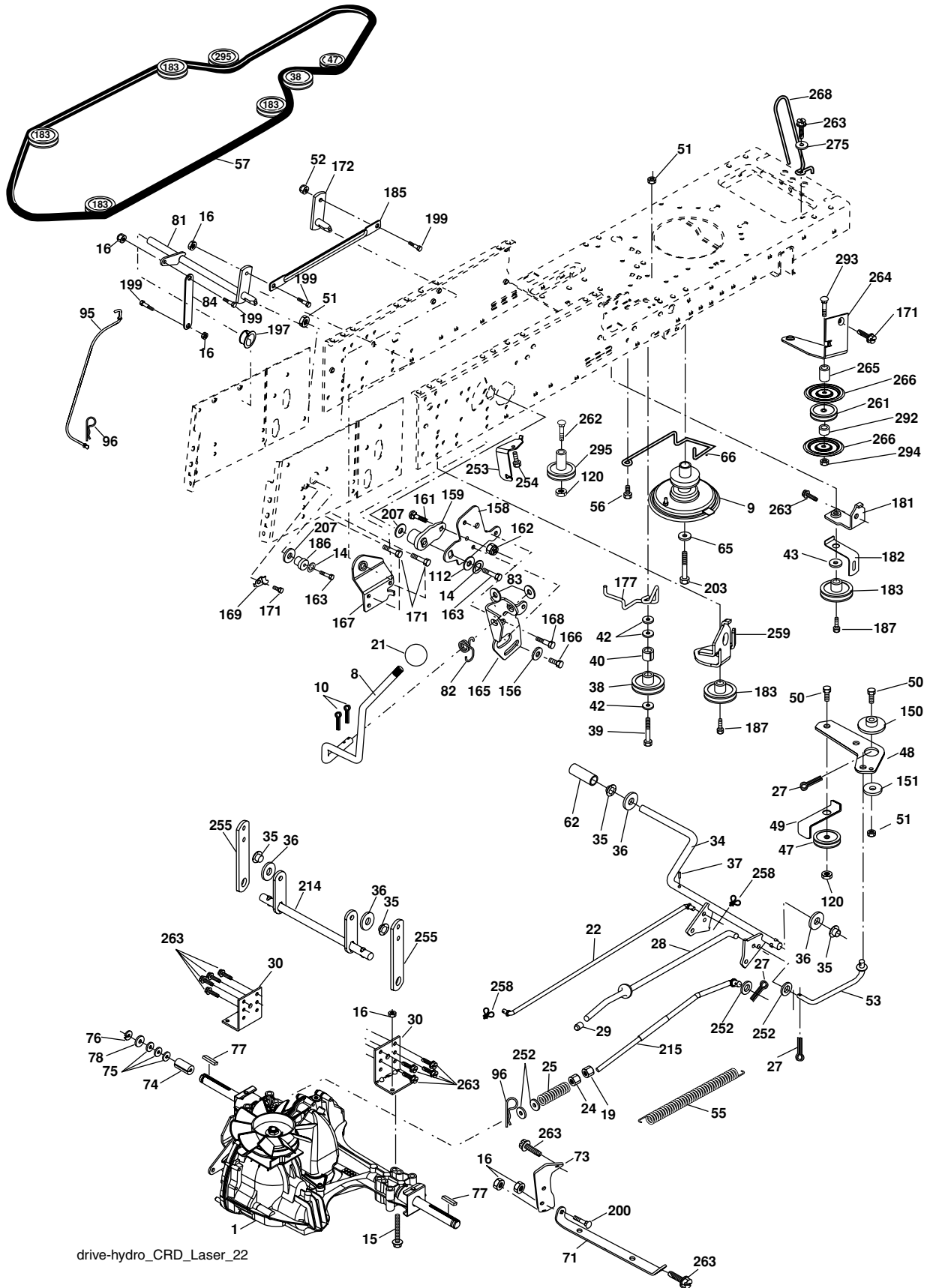

drive-hydro_CRD_Laser_22

REPAIR PARTS

**TRACTOR - - MODEL NO. M155B107HRB (96061010000), PRODUCT NO.960 61 01-00
DRIVE**

KEY NO.	PART NO.	DESCRIPTION	KEY NO.	PART NO.	DESCRIPTION
1	-----	Transaxle Hydro Gear 321-0510 (Order parts from transaxle manufacturer)	112	819 09 12-10	Washer 9/32 x 3/4 x 10 Ga.
8	532 19 27-06	Rod, Shift Fender Adjust Lt	120	873 90 06-00	Nut Lock Flg. 3/8-16 unc
9	532 18 03-54	Clutch Asm Noram	150	532 16 58-50	Bushing, Bellcrank Grnd Dr
10	876 02 04-16	Pin, Cotter 1/8 x 1	151	819 13 32-10	Washer 13/32 x 2 x 10 Ga.
14	810 04 04-00	Washer, Lock Hvy Helical	156	532 16 60-02	Washer Srrted 5/16 ID x 1.125
15	874 49 05-44	Bolt Hex FGHD 5/16-18 x Gr 5	158	532 16 55-89	Bracket Shift Mount
16	873 80 05-00	Nut Lock Hex W/Ins 5/16-18 unc	159	532 18 39-00	Hub Shift
19	873 80 06-00	Nut Lock Hex w/Ins 3/8-16 unc	161	872 14 04-06	Bolt Rdhd Sqnk 1/4-20 x 3/4 Gr 5
21	532 10 69-33	Knob	162	873 68 04-00	Nut Crownlock 1/4-20 unc
22	532 17 56-07	Nut	163	874 78 04-16	Bolt Hex Fin 1/4-20 unc x 1 Gr 5
24	873 35 06-00	Nut Hex Jam 3/8-16 unc	165	532 16 56-23	Bracket Pivot Lever
25	532 19 20-36	Spring, Rod, Brake	166	817 49 05-10	Screw 5/16-18 x 5/8
27	876 02 04-12	Pin, Cotter 1/8 x 3/4	167	532 16 55-88	Bracket Support Shift CRD
28	532 17 57-65	Rod, Parking Brake	168	532 16 54-92	Bolt Shoulder 5/16-18 x .561
29	532 07 16-73	Cap, Parking Brake	169	532 16 55-80	Plate Fastening Lt
30	532 16 95-92	Bracket, Mfg. Transaxle	171	817 49 06-08	Screw Thdrol 3/8-16 x 1/2 Ty-Tt
34	532 17 55-78	Shaft, Asm Pedal Foot CRD	172	532 17 02-71	Shaft Asm Shifter Frt CRD
35	532 12 01-83	Bearing, Nylon	177	532 16 59-32	Keeper Flat Idler 3.06" CRD
36	819 21 16-16	Washer 21/32 x 1 x 16 Ga.	181	532 18 02-11	Bracket Idler Ground Drive CRD
37	532 12 49-63	Pin, Roll 3/16 x 1"	182	532 18 26-82	Keeper Belt 2.5" Od V-Idler CRD
38	532 16 59-36	Pulley Flat Composite 3.06"	183	532 19 95-32	Pulley V-Idler CRD
39	874 76 06-44	Bolt Fin Hex 3/8-16 unc x 2-3/4	185	532 17 00-08	Link Shift
40	532 12 49-65	Spacer, Split 395 x 59 Bzp	186	532 16 56-14	Hub Tapered Round CRD
42	819 13 13-12	Washer 13/32 x 13/16 x 12 Ga.	187	817 58 05-20	Screw Thdrol 5/16-18 x 1.25
43	819 11 10-12	Washer 11/32 x 5/8 x 12 Ga.	197	532 16 96-13	Nyliner Snap-In 5/8
47	532 12 77-83	Pulley, Idler, V Groove Plasic	199	532 16 96-12	Bolt Shoulder 5/16-18 unc
48	532 15 44-07	Bellcrank Clutch Grnd Drv	200	872 14 05-08	Bolt RDHD SQNK 5/16-18 x 1
49	532 12 32-05	Retainer, Belt Style Spring	203	871 17 07-80	Bolt Hex 7/16-20 x 5
50	872 11 06-12	Bolt Carr. Sh. 3/8-16 x 1-1/2 Gr. 5	207	532 16 98-45	Washer Nylon Rear
51	873 68 06-00	Nut, Crownlock 3/8-16 unc	214	532 17 56-09	Shaft Asm. Brake
52	873 68 05-00	Nut Crownlock 5/16-18	215	532 17 56-52	Rod Brake Hydro
53	532 19 96-52	Link, Clutch 7.66	252	819 13 16-16	Washer 13/32 x 1 x 16 Ga.
55	532 10 57-09	Spring, Return, Clutch	253	532 17 50-28	Bracket Cable Chassis
56	817 06 06-20	Screw 3/8-16 x 1-1/4	254	817 00 06-16	Screw 3/8-16 x 1
57	532 17 01-40	V-Belt Kev 112" 0650 CRD	255	532 17 56-08	Brace Shaft Brake Mtg.
62	532 12 48-72	Cover, Pedal	258	532 17 80-62	Clip Retainer
65	810 04 07-00	Washer	259	532 18 02-12	Bracket Pulley
66	532 15 47-78	Keeper, Belt Engine F-Proof	261	532 13 14-94	Pulley Idler
71	532 16 91-83	Strap, Torque, Lh	262	872 11 06-22	Bolt Carr. 3/8-16 x 2-3/4 Gr.5
73	532 16 91-82	Strap, Torque, Rh	263	817 00 06-12	Screw 3/8-16 x 3/4
74	532 13 70-57	Spacer, Split	264	532 19 76-08	Bracket Idler Chassis
75	532 12 17-49	Washer 25/32 x 1-1/4 x 16 Ga.	265	532 18 20-13	Spacer Idler Chassis
76	812 00 00-01	Ring, E	266	532 18 20-61	Shield Idler Mower
77	532 12 35-83	Key, Square	268	532 18 24-02	Guard Muffler RH
78	532 12 17-48	Washer 25/32 x 1-5/8 x 16 Ga.	275	819 13 16-14	Washer 13/32 x 1 x 14 Ga.
81	532 17 00-06	Asm, Shaft,Cross Rear	292	532 40 02-71	Spacer Noram
82	532 16 57-11	Spring, Torsion	293	872 14 06-28	Bolt 3/8-16 x 3-1/2
83	819 17 12-16	Washer 17/32 x 3/4 x 16 Ga.	294	532 19 70-33	Nut 3/8-16
84	532 17 00-07	Link, Transaxle	295	532 17 91-14	Pulley Idler Composite
95	532 17 00-15	Control Asm Bypass Hydro			
96	532 12 47-88	Spring, Retainer 1"			

NOTE: All component dimensions given in U.S. inches
1 inch = 25.4 mm

REPAIR PARTS

TRACTOR -- MODEL NO. M155B107HRB (9606101000), PRODUCT NO.960 61 01-00
STEERING ASSEMBLY

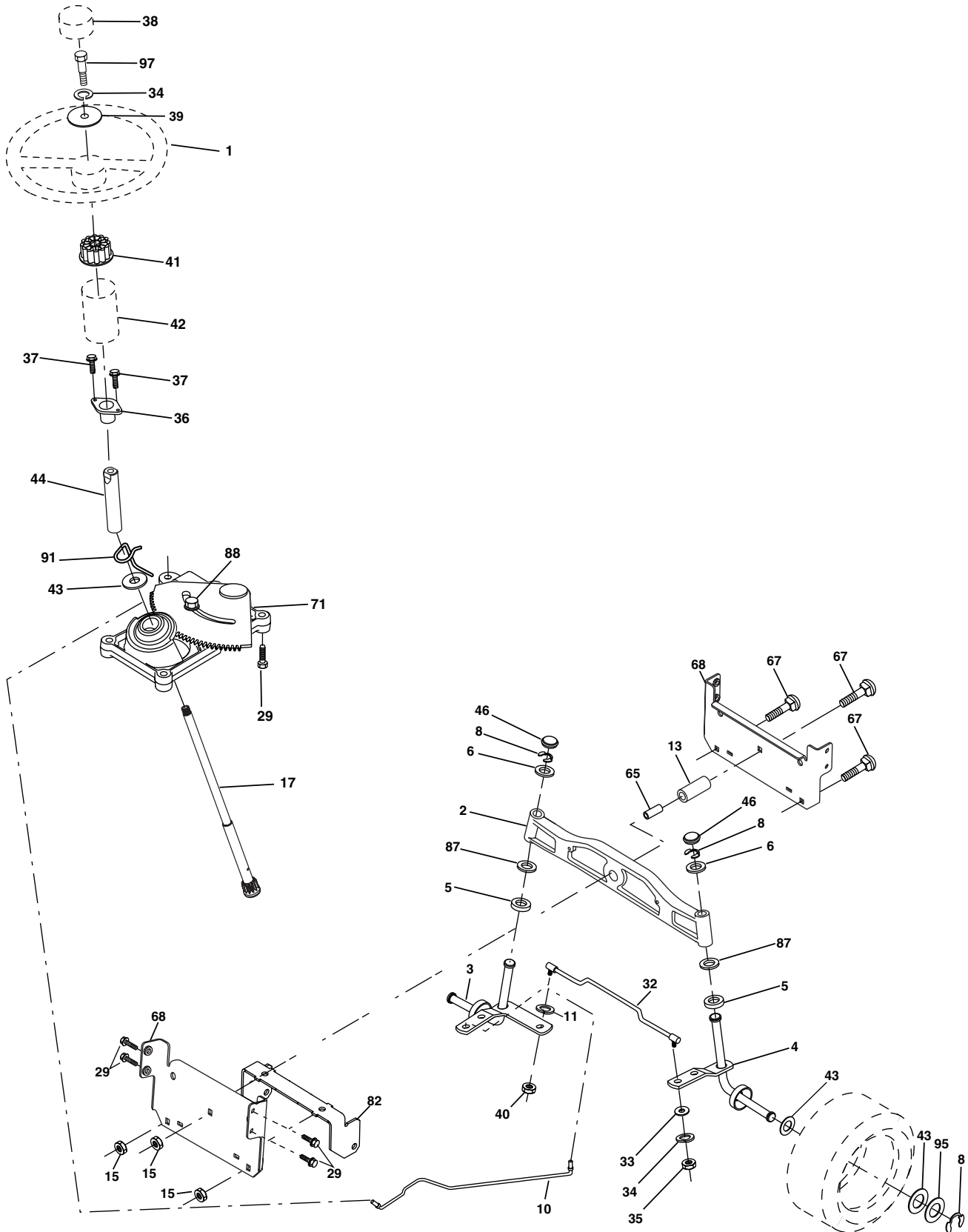

steering_pl.lt_60

REPAIR PARTS

TRACTOR - - MODEL NO. M155B107HRB (96061010000), PRODUCT NO.960 61 01-00
STEERING ASSEMBLY

KEY NO.	PART NO.	DESCRIPTION
1	532 19 45-95	Steering Wheel
2	532 18 47-06	Cast Iron Axle Assembly
3	532 16 98-40	Spindle Assembly, L.H.
4	532 16 98-39	Spindle Assembly, R.H.
5	532 12 49-31	Bearing, Race, Thrust, Hardened
6	532 12 17-48	Washer 25/32 x 1-5/8 x 16 Ga.
8	812 00 00-29	Ring, Klip
10	532 17 51-21	Link, Drag
11	810 04 06-00	Washer, Lock
13	532 13 65-18	Spacer Brg Axle Front
15	532 14 52-12	Nut, Hexflange Lock
17	532 19 07-53	Shaft Assembly, Steering
29	817 00 06-12	Screw, 3/8-16 x 3/4
32	532 17 01-62	Rod, Tie
33	819 11 12-16	Washer 11/32 x 3/4 x 16 Ga.
34	810 04 05-00	Washer Lock Hvy Hlcl Spr 5/16
35	873 54 05-00	Nut Crownlock 5/16-24 unf
36	532 15 50-99	Bushing, Steering
37	532 15 29-27	Screw TT #10-32 x 5 x 3/8 Flange
38	532 19 46-03	Cap Wheel Steer
39	819 11-38-12	Washer 11/32 ID x 2-3/8 OD 12 Ga.
40	873 54 06-00	Nut Crownlock 3/8-24
41	532 18 67-37	Adaptor, Steering Wheel
42	532 16 96-33	Boot, Steering Dash P/L Mtl
43	532 12 17-49	Washer 25/32 x 1-1/4 x 16 Ga.
44	532 19 07-52	Extension Steering
46	532 12 12-32	Cap, Spindle
65	532 16 03-67	Spacer Brace Axle
67	872 11 06-18	Bolt Rdhd Sq 3/8-16 unc x 2-1/4
71	532 17 51-46	Steering Asm.
68	532 16 98-27	Brace Axle
82	532 19 99-78	Bracket Susp Chassis Front
87	532 17 39-66	Washer Flat .781 x 1-1/2 x .14
88	532 17 51-18	Bolt Shoulder 7/16-20 unc
91	532 17 55-53	Clip Steering
95	532 18 89-67	Washer Harden .793 x 1.637 x 060
97	874 78 05-64	Bolt 5/16-18 unc x 4" L Gr.5

NOTE: All component dimensions given in U.S. inches.
1 inch = 25.4 mm.

REPAIR PARTS

TRACTOR -- MODEL NO. M155B107HRB (9606101000), PRODUCT NO.960 61 01-00
ENGINE

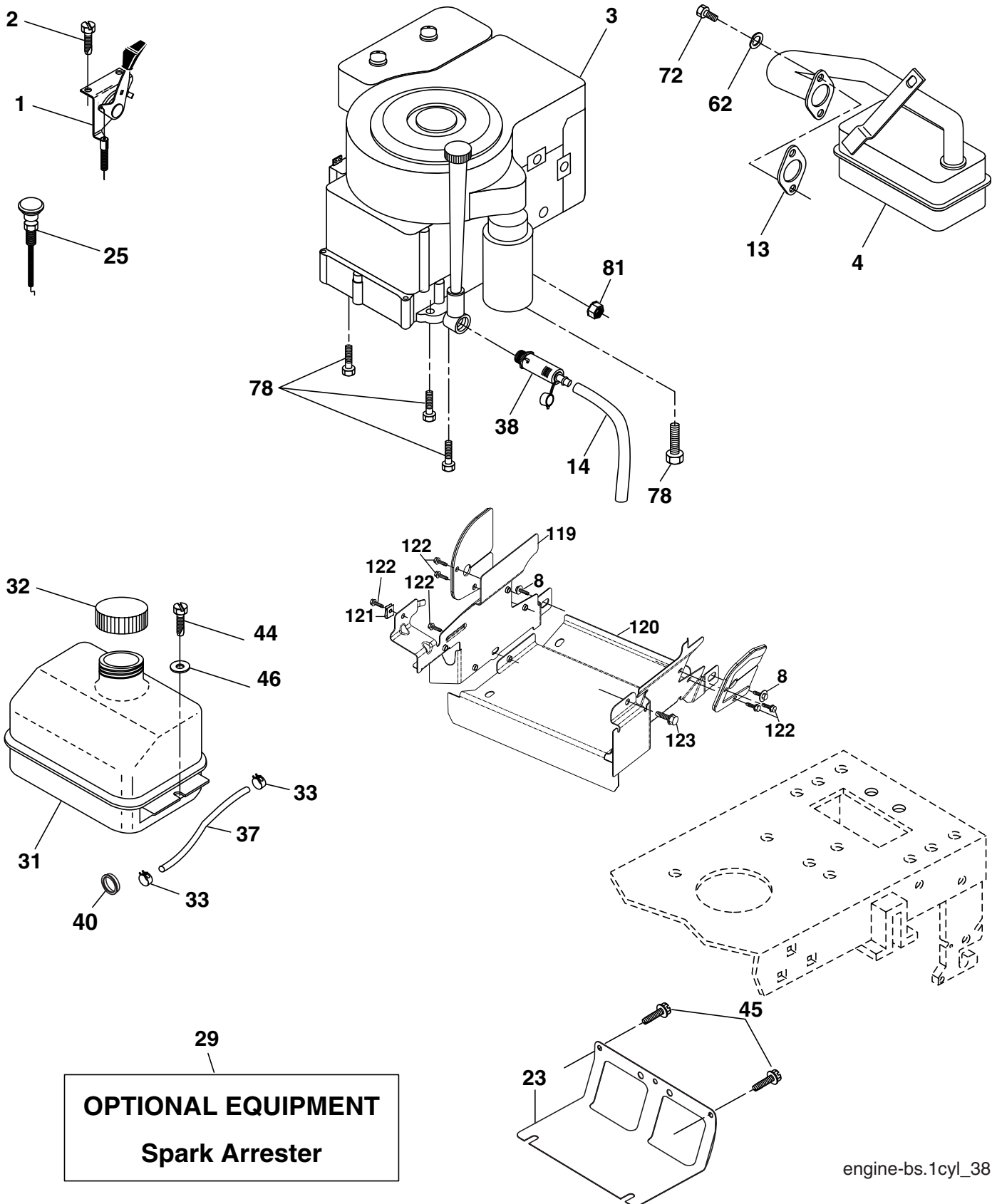

OPTIONAL EQUIPMENT
Spark Arrester

engine-bs.1cyl_38

REPAIR PARTS

TRACTOR - - MODEL NO. M155B107HRB (96061010000), PRODUCT NO.960 61 01-00
ENGINE

KEY NO.	PART NO.	DESCRIPTION
1	532 17 05-51	Control Throt /Ch
2	817 72 04-08	Screw Hex Thd Cut 1/4-20 x 5/8 T
3	-----	Engine B&S Model 282H070 (Order Parts from Engine Manufacturer)
4	532 13 73-52	Muffler Exhaust B&S LT
8	532 17 18-77	Bolt 5/16-18 unc x 3/4
13	532 16 52-91	Gasket 1 313 Id Tin Plated
14	532 14 84-56	Tube Drain Oil Easy
23	532 16 98-37	Shield Browning/Debris Guard
25	532 19 06-95	Control Choke 1 Cyl.
29	532 13 71-80	Arrestor Spark
31	532 18 77-50	Tank Fuel
32	532 19 77-25	Cap Asm Fule Top
33	532 12 34-87	Clamp Hose Blk
37	532 13 70-40	Line Fuel 20"
38	532 18 16-54	Plug Drain Oil Easy
40	532 12 40-28	Bushing Snap
44	817 67 04-12	Screw Hexwsh Thdrol 3/8-16 x 3/4
45	817 00 06-12	Screw 3/8-16 x 3/4
46	819 09 14-16	Washer 9/32 x 7/8 x 16 Ga.
62	810 01 05-00	Washer Split
72	532 19 23-34	Screw Socket Head 5/16-18 x 3/4
78	817 06 06-20	Screw 3/8-16 x 1-1/4
81	873 51 04-00	Nut Keps Hex 1/4-20 unc
119	532 40 06-01	Guard Asm. Eng. LH
120	532 40 06-00	Guard Asm. Eng. RH
121	532 19 66-88	Chips Threaded
122	532 13 77-29	Screw Thd Roll 1/4-20 x 5/8
123	817 67 05-08	Screw Thdrol 5/16-18 x 1/2

NOTE: All component dimensions given in U.S. inches
1 inch = 25.4 mm

REPAIR PARTS

TRACTOR - - MODEL NO. M155B107HRB (9606101000), PRODUCT NO.960 61 01-00
SEAT ASSEMBLY

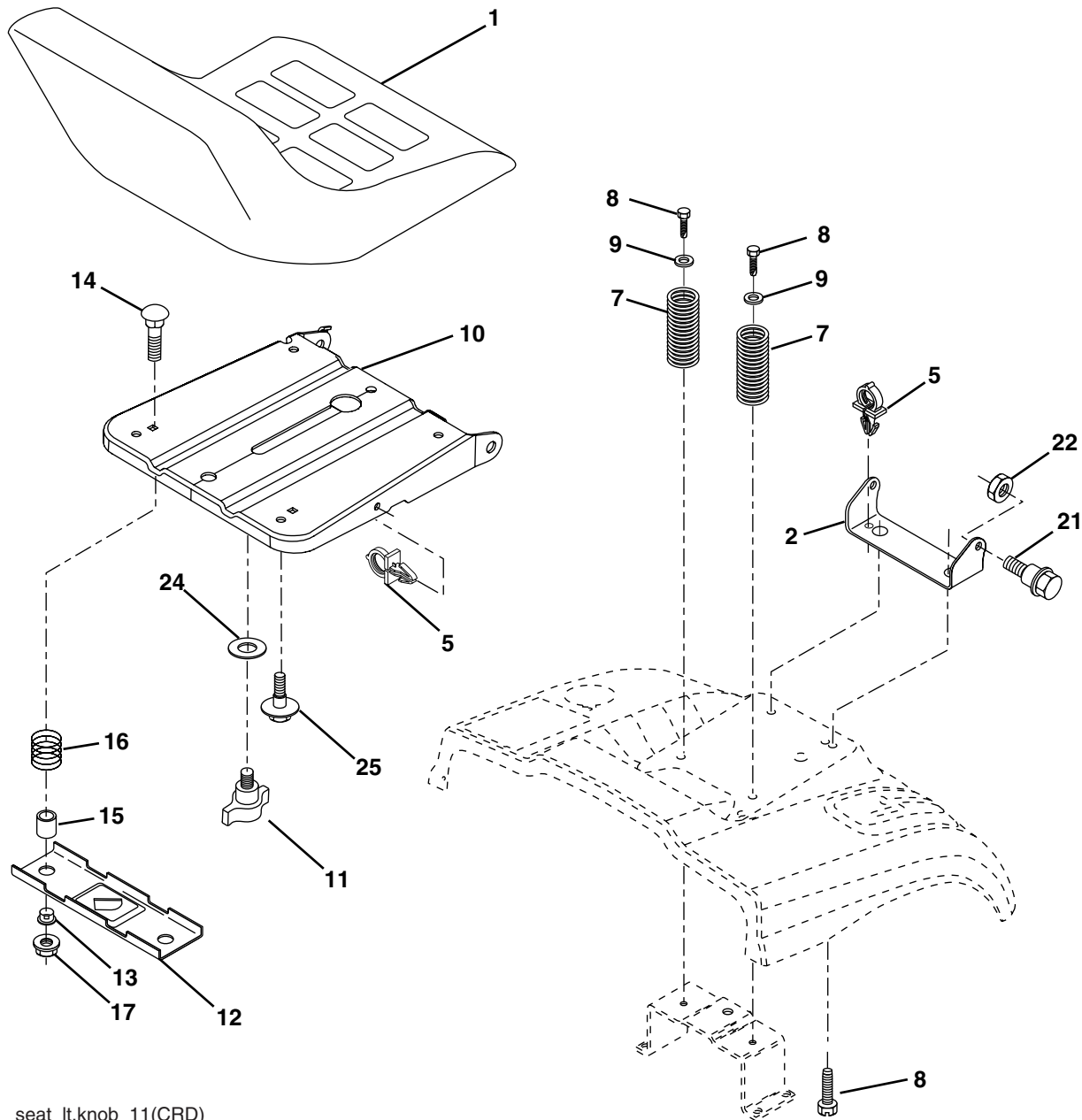

seat_lt.knob_11(CRD)

KEY NO.	PART NO.	DESCRIPTION
1	532 18 87-13	Seat
2	532 14 05-51	Bracket Pnt Pivot Seat (blk)
3	871 11 06-16	Bolt Fin Hex 3/8-16 unc x 1
4	819 13 16-10	Washer Flat 13/32 x 1 x 10 Ga.
5	532 14 50-06	Clip Push In Hinged
6	873 80 06-00	Nut Lock Hex 3/8-16 unc
7	532 12 41-81	Spring Seat Cprsn 2 250 Blk Zi
8	817 00 06-16	Screw 3/8-16 x 1-1/2
9	819 13 16-14	Washer 13/32 x 1 x 14 Ga.
10	532 19 55-30	Pan Pnt Seat (blk)
11	532 16 63-69	Knob Seat

KEY NO.	PART NO.	DESCRIPTION
12	532 17 46-48	Bracket Pnt Mounting Switch
13	532 12 12-48	Bushing Snap Blk Nyl 50 Id
14	872 05 04-12	Bolt Rdhd Sht Nk 1/4-20 x 1-1/2
15	532 13 43-00	Spacer Split
16	532 12 12-50	Spring Cprsn
17	532 12 39-76	Nut Lock 1/4 Lge Flg Gr. 5 Zinc
21	532 17 18-52	Bolt Shoulder 5/16-18 unc-2A
22	873 80 05-00	Nut Hex Lock w/Ins 5/16-18
24	819 17 19-12	Washer 17/32 x 1-3/16 x 12 Ga.
25	532 12 70-18	Bolt Shoulder 5/16-18 x .62

NOTE: All component dimensions given in U.S. inches.
1 inch = 25.4 mm

REPAIR PARTS

TRACTOR - - MODEL NO. M155B107HRB (96061010000), PRODUCT NO.960 61 01-00
MOWER LIFT

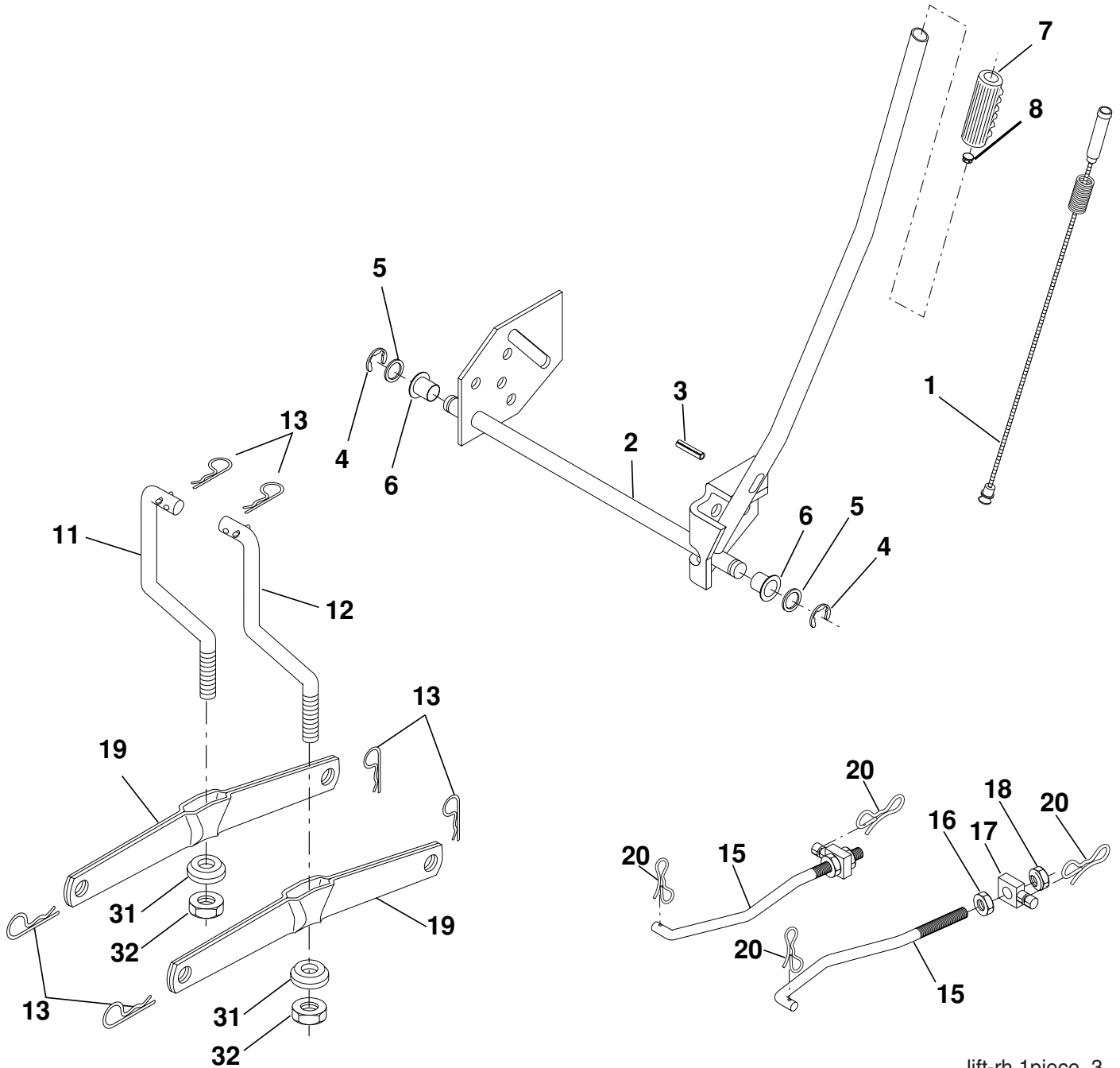

lift-rh.1piece_3

KEY NO.	PART NO.	DESCRIPTION
1	532 19 84-17	Washer Asm Inner Spring W/ Plunger
2	532 19 80-70	Shaft Asm. Lift
3	532 18 88-22	Pin Groove
4	812 00 00-02	E Ring #5133-62
5	819 21 16-21	Washer 21/32 x 1 x 21 Ga.
6	532 12 01-83	Bearing Nylon
7	532 10 94-13	Grip Handle Bicycle
8	532 12 45-26	Button Plunger Black
11	532 16 58-29	Link Asm Lift L.H.
12	532 16 58-31	Link Asm Lift R.H.
13	532 12 46-70	Retainer Spring

KEY NO.	PART NO.	DESCRIPTION
15	532 17 32-88	Link Front
16	873 35 08-00	Nut Jam Hex 1/2-13 unc
17	532 17 56-89	Trunnion Blk Zinc
18	873 80 08-00	Nut Lock w/Wsh 1/2-13 unc
19	532 13 98-68	Arm Suspension Mower
20	532 19 42-09	Pin Cotter 7/16 Bowtie Lock
31	532 16 98-65	Bearing, Pvt. Lift.
32	873 54 06-00	Nut Crownlock 3/8-24

NOTE: All component dimensions given in U.S. inches
1 inch = 25.4 mm

REPAIR PARTS

TRACTOR -- MODEL NO. M155B107HRB (9606101000), PRODUCT NO.960 61 01-00
MOWER

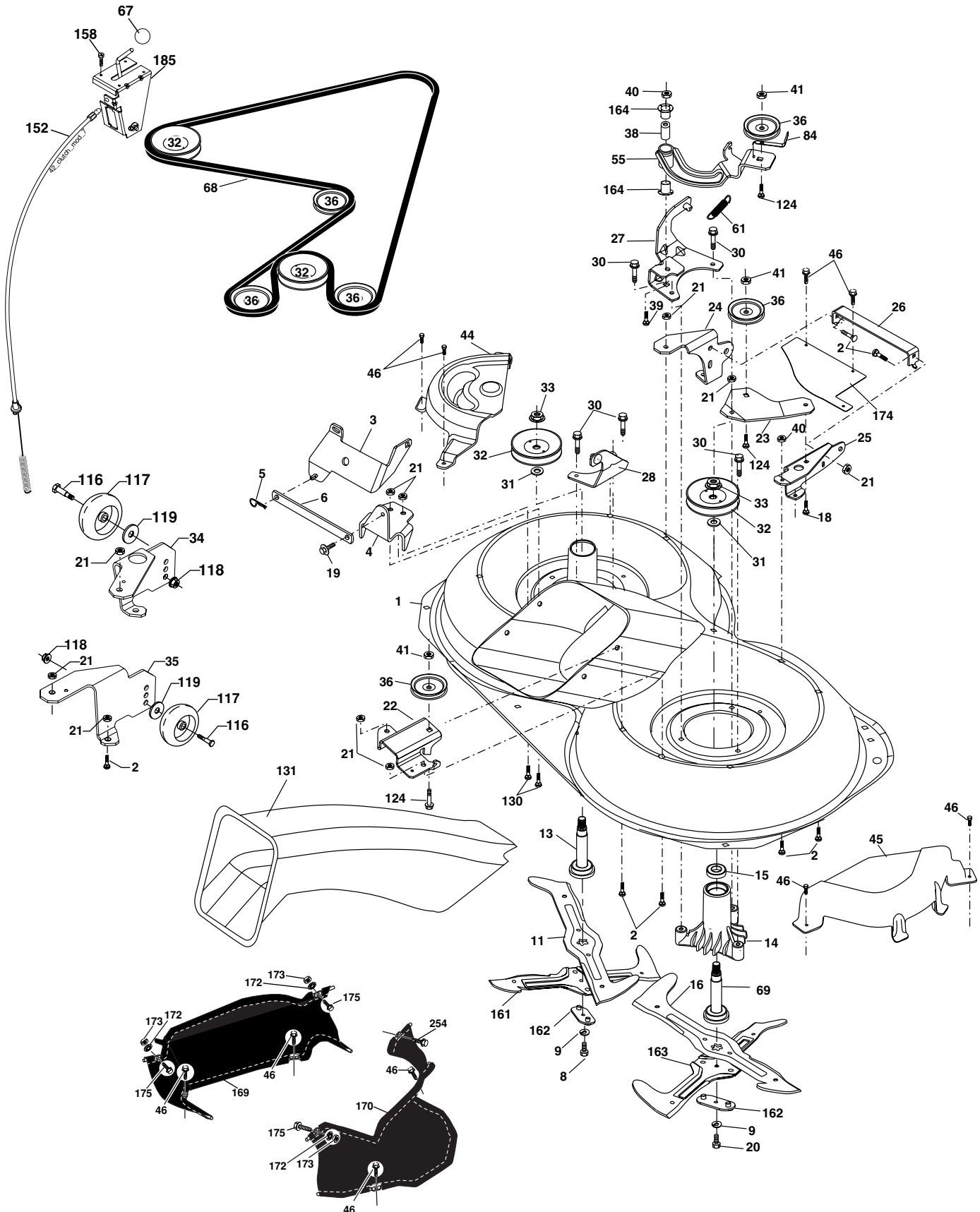

REPAIR PARTS

TRACTOR - - MODEL NO. M155B107HRB (96061010000), PRODUCT NO.960 61 01-00
MOWER

KEY NO.	PART NO.	DESCRIPTION	KEY NO.	PART NO.	DESCRIPTION
1	532 16 91-60	Housing Asm. Mower	44	532 17 55-38	Cover Mandrel Lh
2	872 14 05-06	Bolt Rdhd Sqnk 5/16-18 unc x 3/4	45	532 17 55-39	Cover Mandrel Rh
3	532 16 55-69	Bracket Asm. S-Bar Chass	46	532 13 77-29	Screw Thd Roll 1/4-20 x 5/8
4	532 16 91-67	Bracket Bar Sway Deck	55	532 16 98-49	Arm Idler
5	532 12 46-70	Retainer Spring	61	532 17 51-59	Spring Tension Belt
6	532 16 55-57	Bar Sway	67	532 10 69-32	Knob
8	532 18 17-12	Bolt 3/8-24 x 1.25 Gr. 8 Patched	68	532 40 20-09	Hex-Belt Mower
9	810 03 06-00	Washer Lock Hvy 3/8 Unplated	69	532 16 54-82	Shaft Asm W/Lwr Brg Rh Thd CRD
11	532 18 05-83	Blade 3-1 Lh	84	532 15 60-85	Keeper Belt Idler
13	532 13 76-45	Shaft Asm. W/Lower Bearing	116	532 18 42-19	Bolt Shoulder
14	532 12 87-74	Housing Mandrel Vented (Machd)	117	532 17 48-73	Wheel Gage
15	532 11 04-85	Bearing Ball Mandrel	118	873 93 06-00	Nut Centerlock 3/8-16 unc
16	532 18 05-84	Blade 3-1 Rh	119	819 12 14-14	Washer 3/8 x 7/8 x 14 Ga.
18	872 11 06-06	Bolt Rdhd Sqnk 3/8-16 x 3/4 Gr. 5	124	872 11 06-12	Bolt Carr Sh 3/8-16 x 1-1/2 Gr5
19	532 13 28-27	Bolt Shoulder 5/16-18 Thd Form	130	872 11 05-06	Bolt Rdhdsqnk 5/16-18 unc x 3/4
20	532 18 17-13	Bolt 3/8-24 x 1.25 Gr. 8 Ptch Lhthd	131	532 16 56-61	Chute Bagger CRD 92cm
21	873 68 05-00	Nut Crown Lock 5/16-18	152	532 17 60-74	Cable Clutch
22	532 16 91-65	Bracket Idler Sprr RR	158	817 72 04-08	Screw 1/4-20 x 1/2
23	532 16 91-66	Bracket Idler Sprr RF	161	532 18 04-24	Blade Cross LH 107
24	532 16 91-70	Bracket Suspension LF	162	532 18 08-78	Adapter Weldment Blade 107
25	532 40 01-05	Bracket Suspension RF	163	532 18 04-25	Blade Cross RH 107
26	532 40 01-10	Brace Susp Frt CRD	164	532 12 49-37	Bearing
27	532 16 91-72	Bracket Asm. Susp RR	169	532 40 02-76	Module Guard Asm. Fbr. CRD LH
28	532 16 91-68	Bracket Asm. Susp LR	170	532 40 02-77	Module Guard Asm. Fbr. CRD RH
30	532 17 39-84	Screw Thd Rolling Dod.PT Hex	172	532 40 12-20	Push Nut Rd 3/8 Diam.
31	532 18 76-90	Washer Spacer Mower Vented	173	873 80 06-00	Nut Lock Hex w/Ins. 3/8-16 unc
32	532 17 57-07	Mandrel Pulleys	174	532 40 02-40	Guard Suspension Front
33	532 40 02-34	Nut Flg Top Lock	175	872 11 06-08	bolt Rdhd Sqnk 3/8-16 x 1 Gr. 5
34	532 40 01-03	Bracket Gauge Wheel Lf	185	532 18 82-34	Head Asm Cable Clutch
35	532 40 01-04	Bracket Gauge Wheel Rf	254	817 00 06-16	Screw 3/8-16 x 1
36	532 14 67-63	Pulley Idler V-Groove Dim 4.25	--	532 18 18-57	Mandrel Asm Service
38	532 16 98-51	Spacer Hub Arm Idler	--	532 18 18-58	Mandrel Asm CRD Lh Threads VC
39	872 11 06-22	Bolt RhHd 3/8-16 unc x 2-3/4 Gr.5	--	532 40 03-18	Replacement Mower Complete
40	873 68 06-00	Nut Crownlock 3/8-16 unc			
41	873 90 06-00	Nut Flangelock 3/8-16 unc			

NOTE: All component dimensions given in U.S. inches
1 inch = 25.4 mm

REPAIR PARTS

TRACTOR - - MODEL NO. M155B107HRB (9606101000), PRODUCT NO.960 61 01-00
BAGGER

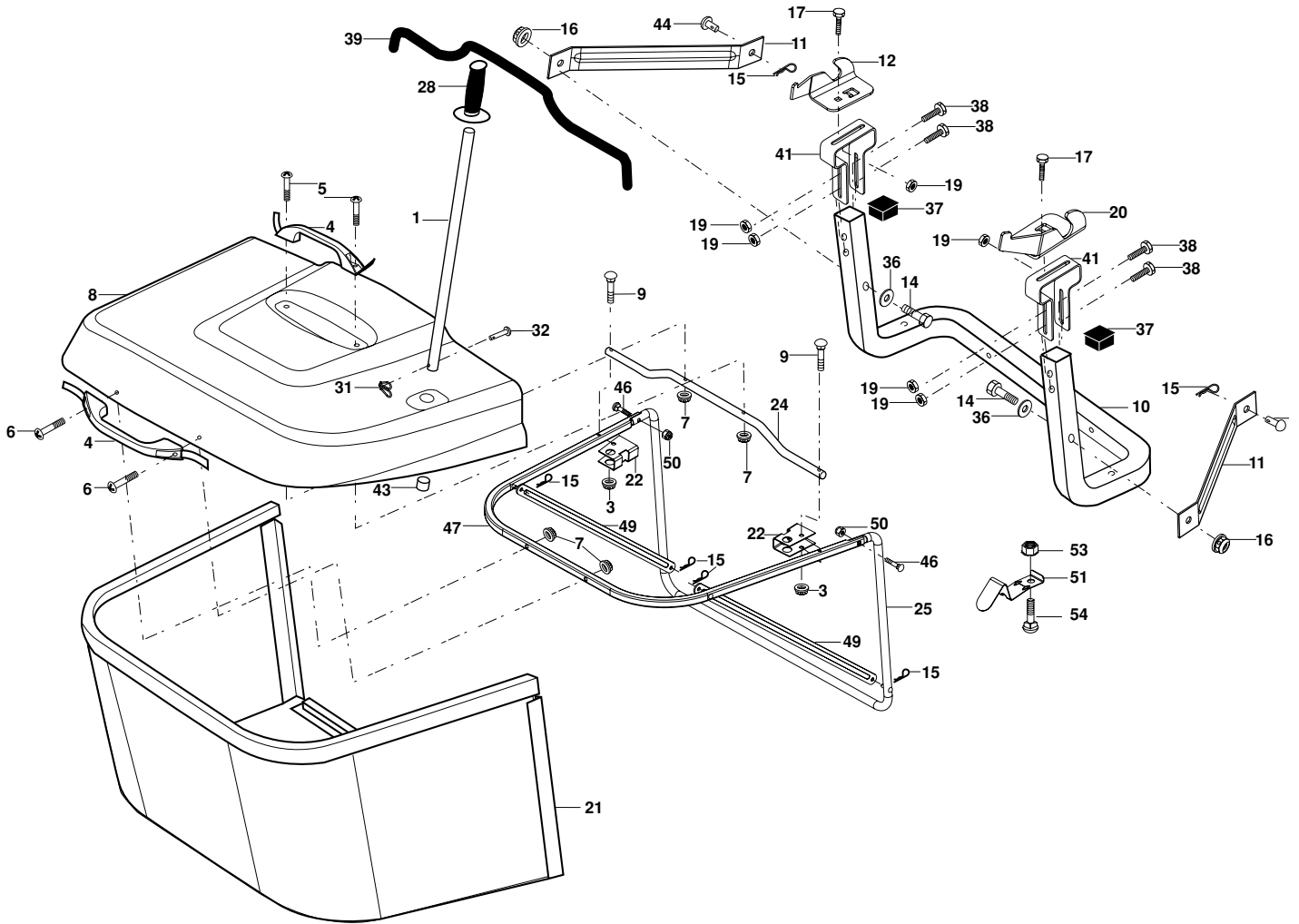

Bagger Asy (CRD)_12

REPAIR PARTS

TRACTOR - - MODEL NO. M155B107HRB (96061010000), PRODUCT NO.960 61 01-00
BAGGER

KEY NO.	PART NO.	DESCRIPTION
1	532 16 52-49	Tube Handle Bagger CRD
3	532 12 39-76	Nut Lock 1/4 Lge Flg Gr. 5 Zinc
4	532 16 99-16	Handle Bagger w/Lvrs Gr. 5 Zinc
5	874 98 10-24	Screw Pan Head #10-24 x 1.50 Blk
6	874 98 10-32	Screw Pan Hd
7	873 40 10-00	Nut Wiz Lock Hex Serr/Hd #10-24
8	532 18 25-14	Cover Bagger Steel
9	872 14 04-18	Bolt Carriage 1/4-20 x 2.25d x Gr. 5
10	532 18 12-82	Tube Support Bagger CRD
11	532 16 57-19	Bracket Support Upper Bag CRD
12	532 18 88-48	Bracket Pivot LH
14	874 52 06-36	Bolt Fin Hex 3/8-16 x 2 x 1/4 Gr.5
15	532 12 46-70	Retainer Spring
16	873 90 06-00	Nut Fock Flg 3/8-16 unc
17	872 14 05-06	Bolt Rdhd Sht Sqnk 5/16-18 unc x 3/4
19	873 90 05-00	Nut Lock Hex Flange 5/16-18
20	532 18 88-47	Bracket Pivot RH
21	532 19 38-38	Bag Asm CRD
22	532 16 57-81	Bracket Side Bagger CRD
24	532 16 57-83	Tube Pivot Bagger CRD
25	532 19 37-05	Tube Front Bagger CRD
28	532 16 57-87	Grip Handle Black
31	532 16 94-84	Retainer Clip
32	532 12 68-75	Rivet Rd Hd Drilled 3/8 Dia
36	819 13 20-12	Washer 13/32 x 1-1/4 x 12 Ga.
37	532 17 54-01	Plug Support Bagger CRD
38	872 01 05-20	Bolt 5/16-18 x 2-1/2
39	532 18 09-85	Seal Trim 37"
41	532 16 96-83	Bracket Vert Adj Bagger CRD
43	532 17 40-83	Plug Tubing End
44	532 19 33-12	Pin Clevis 3/8 x 11/16
46	872 11 05-10	Bolt Carr. 5/16-18 x 1-1/4 Gr.5
47	532 19 37-04	Tube Upper Bagger
49	532 19 33-05	Bar Spreader Bagger
50	873 80 05-00	Nut Lock Hex w/insert 5/16-18 unc
51	532 19 99-03	Latch Spring Bagger
53	873 51 04-00	Nut Keps Hex 1/4-20 unc
54	872 14 04-06	Bolt RDHD SQNK 1/4-20 x 3/4 Gr.5

NOTE: All component dimensions given in U.S. inches
1 inch = 25.4 mm